



Agilent 35181H

Testmobile Printer/Plotter Stand

Installation Guide



Agilent Technologies

November 2001
Printed in U.S.A. E1101



5967-9306

Notice

The information contained in this document is subject to change without notice.

AGILENT TECHNOLOGIES MAKES NO WARRANTY OF ANY KIND WITH REGARD TO THIS MATERIAL, INCLUDING, BUT NOT LIMITED TO, THE IMPLIED WARRANTIES OF MERCHANTABILITY AND FITNESS FOR A PARTICULAR PURPOSE.

Agilent Technologies shall not be liable for errors contained herein or for incidental or consequential damages in connection with the furnishing, performance, or use of this material. This document contains proprietary information, which is protected by copyright. All rights are reserved. No part of this document may be photocopied, reproduced, or translated into another language without the prior written consent of Agilent Technologies.

Copyright © 1998, 2001 Agilent Technologies, Inc.

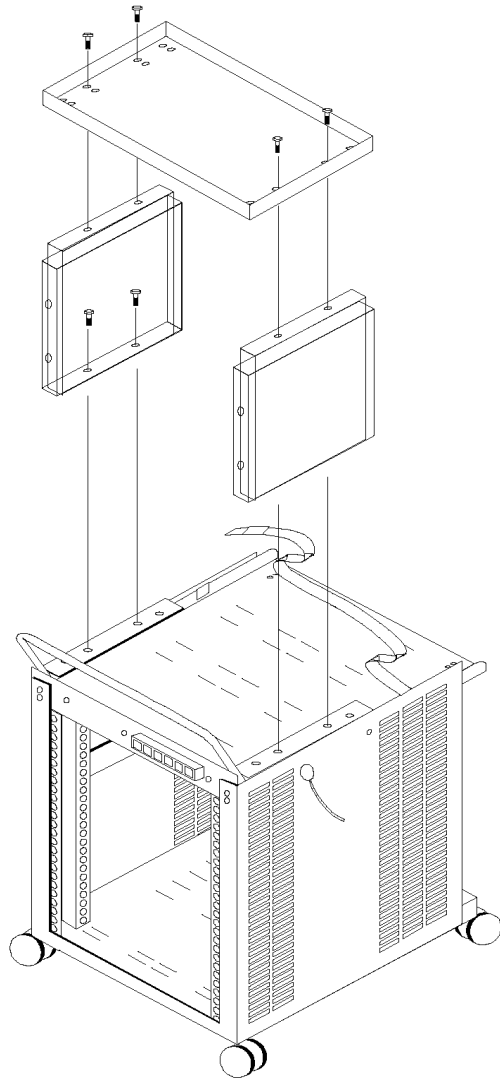

Agilent 1181B

Agilent 1181B

The printer/plotter stand can be assembled in two ways. Rotate and install the side panels for your optimum height requirements. Use four hex nuts and M4 screws to hold the top to the sides.

Note: Please use a T-15 Torx Driver for the M4 screws.